

Solenoid Controls and Monitoring System

Pablo Campero, Mary Ann Antonioli, Peter Bonneau, Brian Eng, Amanda Hoebel, George Jacobs, Mindy Leffel, Tyler Lemon, Marc McMullen, and Amrit Yegneswaran

Physics Division, Thomas Jefferson National Accelerator Facility, Newport News, VA 23606

June 11, 2018

The Hall B Solenoid is a superconducting magnet cooled at 4.5 K, used to provide uniform magnetic field in the beam direction at maximum of 5 T during its maximum energization at 2416 A. To achieve such controlled conditions, the implementation of an instrumentation, controls, and monitoring systems was required.

The Solenoid Controls and Monitoring System (SCMS) runs on an Allen Bradley PLC in conjunction with a National Instruments cRIO system and hardware controllers, Fig 1. The hardware controllers are the Excitation chassis (low voltage chassis), Quench Detector Units, vacuum controllers, liquid level, heater controllers, and temperature monitors.

and magnetic field. Instrumentation is located in the Solenoid itself, Table I, and the Solenoid Service Tower (SST), Table II.

The PLC system consists of two A10 chassis, a local and a remote. The local chassis houses a 1756-L72 controller, three analog input modules, two analog output modules, an E-web module, and an Ethernet module, Fig. 2.

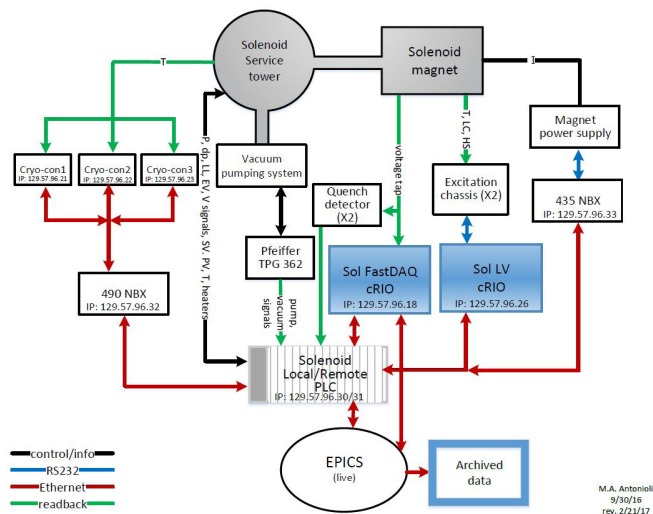

FIG. 2. PLC system local chassis.

The analog input modules read sensor signals from pressure, heaters, helium liquid level (based on differential of pressure) and its probes, lead and magnet reservoir sensors of the SST, flows in the current leads, electric valve positions, and vacuum monitoring.

Analog output modules control mass flow controllers for the current leads and immersion heaters on the lead and magnet reservoirs on the SST.

The E-Web module synchronizes the PLC system time with the Torus PLC, DBX PLC, and cRIO systems, using a JLab server to set the time of the controller every 5 minutes.

The Ethernet module allows PLC communication with Hall B subnet systems, such as the Torus magnet and distribution box (DBX) control systems, EPICS, cRIO, NBX modules, and CryoCon temperature monitors.

FIG. 1. Communications, controls, and monitoring of the Solenoid.

All instrumentation readouts are sent to the PLC and analyzed, appropriate action is taken, and the analyzed data is transmitted to EPICS, which displays the data in real time and archives the data using MYA.

Instrumentation and sensors are used to measure and control process variables for temperatures, forces, pressures, pressure differentials, liquid levels, cryogenic flows, voltages,

Sensor type	Description	Controlled by	Readback signal	Range	Qty
Cernox	temperature	LV chassis/cRIO/PLC	voltage	1.4–325 K	26
PT-100	temperature	LV chassis/cRIO/PLC	voltage	14–325 K	18
load cells	force	LV chassis/cRIO/PLC	voltage	0–10 KN (axial), 0–165 KN (radial)	16
hall probes	magnetic field	LV chassis/cRIO/PLC	voltage	0–4.2 T	3
voltages taps	voltages	QD units/cRIO/PLC	voltage	N/A	21

TABLE I. Solenoid instrumentation and sensors details.

Sensor type	Description	Controlled by	Input/output signal	Range	Qty
Cernox	temperature	Cryocon/PLC	voltage	4.2–325 K 1.4–325 K	20
PT-100	temperature	Cryocon/PLC	voltage	23–1123 K	16
PT	pressure transducers	PLC	4–20 mA	0–75 psia, 0–50 psia	4
liquid levels SC	LHe level superconducting probes	AMI 135 controller/ PLC	0–10 V	0–100%	2
liquid levels DP	differential pressure	PLC	4–20 mA	0–5 inH ₂ O, 0–25 inH ₂ O	2
EV	electric valves	PLC	24 VDC	N/A	4
PV	pneumatic valves	PLC	24 VDC	N/A	1
SV	Solenoid valves	PLC	24 VDC	N/A	3
LVDTs	linear variable differential – valve positions	LVDT/PLC	4–20 mA	0–100%	4
flow	mass flow controller	TELEDYNE MFC/ PLC	4–20 mA	0–150 SLPM	2
reservoir heaters	immersion heaters	Sorensen DML/PLC	4–20 mA/4–20mA, 24 VDC	0–40 W, 0–60 W	2
lead heaters	cartridge heaters	PLC	24 VDC	0–600 W	2

TABLE II. Solenoid Service Tower instrumentation and sensors details.

The remote A10 chassis houses three relay modules, three digital input modules, a sequence of events (SOE) module, and an Ethernet module, Fig 3.



FIG. 3. PLC system remote chassis.

The relay modules control electric, pneumatic, and solenoid valves, cartridge heaters in the current leads, immersion heaters in the magnet and lead reservoirs, hall sensor current polarity, open dump switch on the magnet power supply (MPS), and the MPS CPU reset.

Digital input modules read the status of power source signals, quench detection unit channels, 480-VAC power source to the MPS, interlock summary, and MPS dump switch.

The SOE module detects and timestamps the interlock events of fourteen hardware signals on the interlock system.

The Ethernet module allows data signal transmission from modules in the chassis to the controller in the local chassis.

The local chassis controller program, written in Studio 5000 Logix Designer software, v.27, runs independently of the EPICS and cRIO systems. The primary function of the program is to automate and control Solenoid operations—vacuum generation, cooldown, energization/de-energization, and interlocks. During any of these operations, the controller moves SCMS to a safe state and makes the sensor and instrumentation available to EPICS.

The three PLCs (Solenoid, DBX, and Torus) share cryogenics and magnet status signals. The DBX PLC controls cooldown interlocks and provides temperature and pressure readouts used to calculate cooldown parameters. The Solenoid PLC is configured to interact with the Torus PLC.

The Solenoid PLC acquires data from the cRIO control systems. Temperatures, load cells, and hall sensors in the Solenoid are controlled by the Sol-LV cRIO; voltage taps are measured by the Sol-FastDAQ cRIO.

The Sol-LV cRIO has an NI-9074 controller and LabVIEW code that calculates excitation voltages and currents, sends the calculations via an RS232 module to the low voltage chassis, and reads sensor data sent back from the low voltage chassis. The Sol-LV cRIO sends sensor readouts every second to the PLC via Ethernet.

The Sol-FastDAQ cRIO has an NI-9068 controller and eight analog input modules that read 21 voltage taps. Its LabVIEW control program delivers data at different rates—to the PLC at 5 Hz and to EPICS at 10 KHz. It calculates maximum, minimum, and average of voltage taps' readouts, and scales these readouts to different factors, depending on the voltage tap (20 for VT8_DAQ, VT12_DAQ, and VT14_DAQ; 25 for VT10_DAQ; and 80 for VT20_DAQ). Due to its FPGA and real-time processor, the Sol-FastDAQ cRIO allows faster voltage readout than the PLC.

There are seven sub-systems that control sensors and send signals to the PLC—Cryocon 18i temperature controllers, AMI 135 helium liquid level controllers, Sorensen DML 600 heater programmable power supplies, low voltage chassis, Quench Detector Units, Pfeiffer TPG 362 vacuum controller, and MPS controller board.

Three 8-channel Cryocon 18i units control 13 Cernox and 10 PT-100 temperature sensors located in the SST, vaporizer system, and water current leads.

The Cryocon controllers allow the configuration of different calibration curves required by the Cernox temperature sensors, due to the sensors' sensitive resistance variation when they reach a temperature of ~ 4.5 K. PT-100 sensors are configured with the standard PT100 temperature curves.

Additionally, Cryocon relay outputs are used as hardware interlock protection against temperature increments on the current vapor-cooled leads and splices. All temperature sensor readouts are transmitted by the Cryocon units via Ethernet to the 490NBX gateway module, which then moves the data to the PLC. The PLC updates the readouts every 250 ms.

There are two AMI 135 helium liquid level controllers in the SST, one per reservoir (magnet and lead). Each AMI 135 controls a liquid level sensor by measuring the resistance of a superconductive filament. The current through the sensor maintains the portion of the filament in helium gas in the normal (resistive) state, while the portion in liquid remains in the superconducting state (zero resistance). The resulting voltage along the sensor is proportional to the length of filament above the liquid helium and provides a continuous measure of the helium depth in the reservoir. The controllers send the data through a 0–10 V signal to the PLC to be monitored in real time.

The two Sorensen DML 600 heater programmable power supplies control the immersion heaters on the magnet and lead reservoirs. Each Sorensen DML 600 controls a set of heaters that generates power required in each reservoir—40 W in the lead reservoir and 60 W in the magnet reservoir. Six signals between the Sorensen DML 600 and the heaters control and monitor the heaters, four 4–20 mA signals to set and read the current and voltage over the heaters and two relay (+24 VDC) signals to enable and power on/off the heaters.

Two 28-channel, low voltage chassis read back and send excitation current and voltage to 26 Cernox temperature sensors, 15 PT-100 temperature sensors, 16 load cells, and three hall sensors, all connected to the Solenoid. The low voltage chassis receives excitation current and voltage previously calculated by the Sol-LV-cRIO, sends signals to the sensors, reads the actual values of the sensors, and sends the sensor readout data back to the Sol-LV-cRIO via RS232.

Two Quench Detector Units (each with four channels that are divided into upper and lower sub-channels) and a Danfysik 8500 system power supply detect any quench event. The Quench Detector Units compare different combinations

of 20 voltage tap readouts (connected across the entire magnet, coils, and splices) with the set thresholds of 60 mV and 100 mV. In case of a quench event, the Quench Detector Unit interacts directly with the Danfysik 8500 power supply to put the Solenoid in a safe state by opening the dump switch. A relay output signal communicates the quench to the PLC, which then generates an interlock.

The Solenoid's main vacuum gate valve position is controlled and interlocked by a Pfeiffer TPG362 vacuum controller. Using the signals from two combined gauges (thermocouple/cold cathode), the controller's relays open and close the main vacuum gate pneumatic valve in response to any drastic change in vacuum quality during operations. The turbo pump is controlled by a Pfeiffer DCU 002 Display Control Unit that connects with the pump's attached TC 1200 Electronic Drive Unit.

To protect the vacuum and pressure transducers, the guard vacuum pump's speed that is sent to the PLC is controlled by a MOOG speed controller. A signal conditioner converts the frequency (pump speed) to 4–20 mA signals. The pressure transducer is used to measure the pressure at the guard vacuum pump location. A total of six vacuum signals are wired to the analog and relay PLC modules (Table III) to be scaled and converted into appropriate engineering units and are displayed on the EPICS vacuum screen.

The MPS controller board allows local and remote control of the MPS. It has a front panel with a local display where set and read current, status of the MPS internal interlocks, main power status, and interlock status can be monitored. Front panel controls can turn the MPS on/off and reset the pending internal MPS interlocks. The remote control option allows the Solenoid PLC to take control over the MPS by sending commands to set/read the desired current, monitor and reset the MPS internal interlocks status, and turn on/off the MPS. Communication between the PLC and the MPS controller board is through a 435NBX module, which sends to and receives data from the MPS via RS232 and to and from the PLC via Ethernet. The MPS remote control performed by the PLC is operated from the MPS control EPICS screen.

SCMS was developed and implemented to ensure safe and automatic operation for cooldown and ramp-up/down of the Solenoid and performed very well during the commissioning of the Solenoid to the maximum current of 2416 A.

Instrument/sensor type	Description	Controlled/monitored	Monitored input signal	Qty
CG	combined vacuum gauge	Pfeiffer TPG362/PLC	0–10 V	2
TB	turbo pump speed	Pfeiffer DCU 002/ PLC	0–10 V	1
PV	pneumatic valve	Pfeiffer TPG362/PLC	24 VDC	1
PS	guard vacuum pump	MOOG/PLC	4–20 mA	1
PT	pressure transducer	PLC	4–20 mA	1

TABLE III. Vacuum instrumentation signals monitored.